

ecomarmo

marmoker

GRANITOKER



CASALGRANDE
PADANA
THE GREEN WAY TO PAVE





WALL: statuario altissimo honed cm 120x278 - 47^{1/4}"x109^{1/2}" , metropolis silver cm 120x278 - 47^{1/4}"x109^{1/2}"
FLOOR: statuario altissimo honed cm 120x120 - 47^{1/4}"x47^{1/4}"

marmoker
GRANITOKER



statuario altissimo

COLORI | COLOURS | COULEURS | FARBEN



statuario altissimo



statuario fine



extra oro

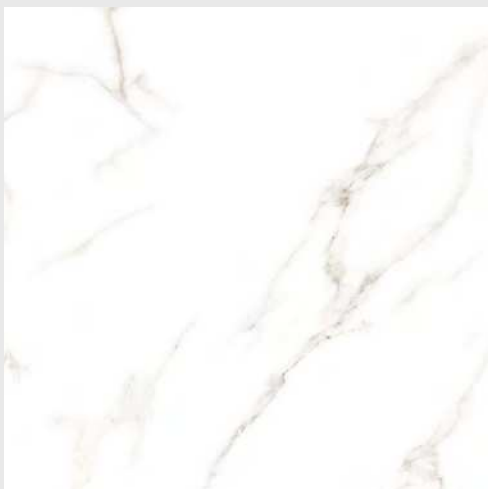

statuario grigio

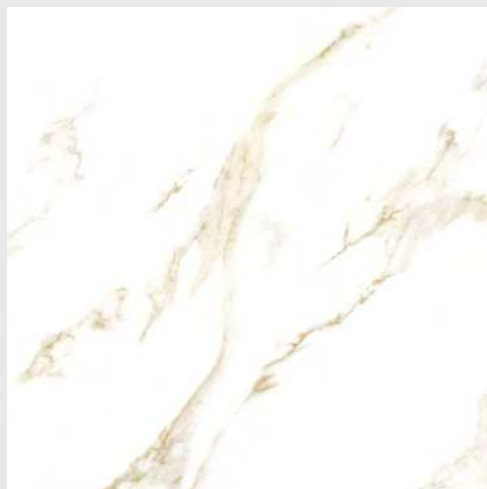

statuario oro



calacatta extra

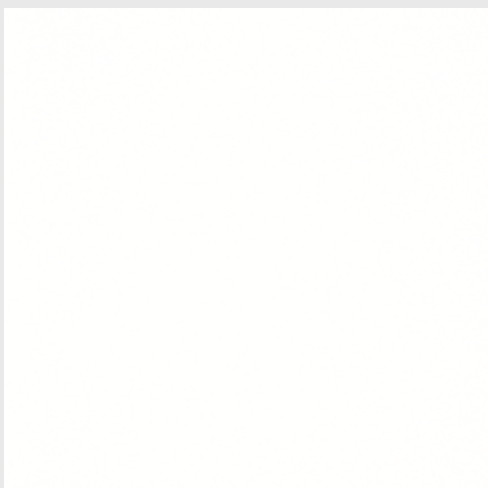

canova



titan white



carrara

[colours >](#)

COLORI | COLOURS | COULEURS | FARBEN



bianco vietnam



crema select



fior di pesco



breccia carsica



bardiglio imperiale



oyster grey



rosso francia



verde aver



caribbean green



pulpis tortora



jolie



grafite



ossidiana

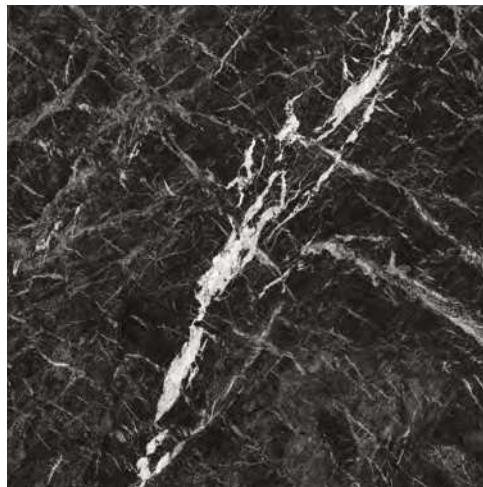

deep dark



starry night

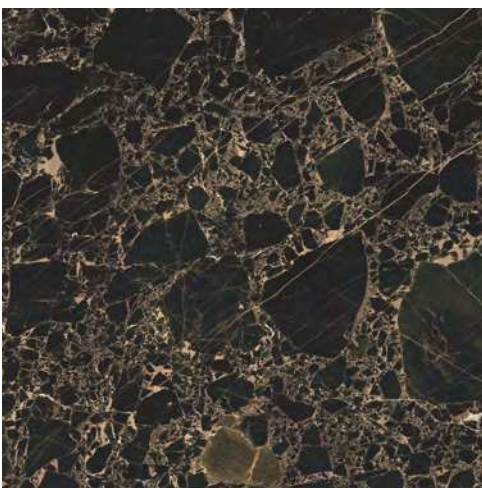

orange black









night storm

FORMATI SPESSORI SUPERFICI | SIZES THICKNESSES SURFACES | FORMATS EPAISSEURS SURFACES | FORMATE SURFACES OBERFLÄCHEN

Caratteristiche tecniche Granitoker a pagina: Granitoker Technical features on page:
 Caractéristiques techniques Granitoker à la page : Granitoker Technische Eigenschaften auf Seite: **526**



| |  |  |  |  |  |  |  |
|--|---|---|---|--|---|---|---|
| Formati Sizes Formats Formate | cm 30x60 11 ^{3/4} "x23 ^{5/8} " | cm 60x60 23 ^{5/8} "x23 ^{5/8} " | cm 60x120 23 ^{5/8} "x47 ^{1/4} " | cm 120x120 47 ^{1/4} "x47 ^{1/4} " | cm 45x90 17 ^{3/4} "x35 ^{3/8} " | cm 90x90 35 ^{3/8} "x35 ^{3/8} " | cm 90x180 35 ^{3/8} "x70 ^{7/8} " |
| Spessori Thicknesses Epaisseurs Stärken | mm 9 | mm 9 | mm 9 | mm 9 | mm 10 | mm 10 | mm 10 |
| Bardiglio Imperiale | ●● | ●● | ●● | | | | |
| Bianco Vietnam | | | | | ●● | ●● | ●● |
| Breccia Carsica | ●● | ●● | ●● | | ●● | ●● | ●● |
| Calacatta Extra | ●●● | ●●● | ●●● | | ●● | ●● | ●● |
| Canova | ●● | ●● | ●● | | | | |
| Caribbean Green | ●● | ●● | ●● | | | | |
| Carrara | ●● | ●● | ●● | ●● | ●● | ●● | ●● |
| Crema Select | ●● | ●● | ●● | | | | |
| Deep Dark | ●● | ●● | ●● | | ●● | ●● | ●● |
| Extra Oro | ●● | ●● | ●● | ●● | ●● | ●● | ●● |
| Fior di Pesco | ●● | ●● | ●● | | | | |
| Grafite | ●●● | ●●● | ●●● | | ●● | ●● | ●● |
| Jolie | ●● | ●● | ●● | | ●● | ●● | ●● |
| Night Storm | ●● | ●● | ●● | | ●● | ●● | ●● |
| Orange Black | ●● | ●● | ●● | | | | |
| Ossidiana | ●● | ●● | ●● | | | | |
| Oyster Grey | ●● | ●● | ●● | | | | |
| Pulpis Tortora | ●● | ●● | ●● | | | | |
| Rosso Francia | | | | | | | |
| Starry Night | ●● | ●● | ●● | | ●● | ●● | ●● |
| Statuario Altissimo | ●● | ●● | ●● | ●● | ●● | ●● | ●● |
| Statuario Fine | ●● | ●● | ●● | ●● | ●● | ●● | ●● |
| Statuario Grigio | ●●● | ●●● | ●●● | ●● | ●● | ●● | ●● |
| Statuario Oro | ●●● | ●●● | ●●● | ●● | ●● | ●● | ●● |
| Titan White | ●● | ●● | ●● | | ●● | ●● | ●● |
| Verde Aver | ●● | ●● | ●● | | ●● | ●● | ●● |

Rettificate monocalibro Rectified monocaliber Rectifiés calibre unique Rektifiziert Monokaliber

** Non idonea per destinazione d'uso spiaggia piscina e/o spogliatoi Not suitable for use for pool decks and/or changing rooms
 Ne convient pas pour une destination d'usage comme plage de piscine et / ou vestiaire Nicht geeignet für Schwimmbeckenränder und/oder Umkleidekabinen

● BS 7976-2:2002 + A1:2013_Valore indicativo, superficie bagnata ed asciutta Approx value, wet and dry surface
 Valeur approximative, surface humide et sèche Näherungswert, nasse und trockene Oberfläche

- Honed **R9**
- Honed **R10 A+B PTV > 36** ** ●
- Lucida

| Formati Sizes Formats Formate | cm 60x120 23 ^{5/8} "x47 ^{1/4} " | cm 120x120 47 ^{1/4} "x47 ^{1/4} " | cm 120x240 47 ^{1/4} "x94 ^{1/2} " | cm 120x278 47 ^{1/4} "x109 ^{1/2} " | cm 160x320 63"x126" | cm 160x320 63"x126" |
|--|---|--|--|---|-------------------------------|-------------------------------|
| Spessori Thicknesses Epaisseurs Stärken | mm 6 | mm 6 | mm 6 | mm 6 | mm 6 | mm 12 * |
| Bardiglio Imperiale | ● ● | ● ● | ● ● | | | |
| Bianco Vietnam | ● ● | ● ● | ● ● | | | |
| Breccia Carsica | | | | | | |
| Calacatta Extra | ● ● | ● ● | ● ● | ● ● +BM | ● ● | ● ● BM |
| Canova | ● ● | ● ● | ● ● | ● ● | ● ● | ● ● |
| Caribbean Green | ● ● | ● ● | ● ● | | | |
| Carrara | ● ● | ● ● | | ● ● | | ● ● BM |
| Crema Select | | | | | | |
| Deep Dark | ● ● | ● ● | | ● ● | | ● ● BM |
| Extra Oro | ● ● | ● ● | | ● ● +BM | | ● ● BM |
| Fior di Pesco | ● ● | ● ● | ● ● +BM | | | |
| Grafite | ● ● | ● ● | ● ● | ● ● | ● ● | ● ● |
| Jolie | | | | | | |
| Night Storm | ● ● | ● ● | ● ● | ● ● | ● ● | ● ● BM |
| Orange Black | ● ● | ● ● | ● ● | | | |
| Ossidiana | ● ● | ● ● | ● ● | ● ● | ● ● | ● ● |
| Oyster Grey | ● ● | ● ● | ● ● | ● ● | | |
| Pulpis Tortora | ● ● | ● ● | ● ● | | | |
| Rosso Francia | | | ● ● | | | |
| Starry Night | ● ● | ● ● | | ● ● | | ● ● BM |
| Statuario Altissimo | ● ● | ● ● | | ● ● +BM | | ● ● BM |
| Statuario Fine | ● ● | ● ● | | ● ● +BM | | ● ● BM |
| Statuario Grigio | ● ● | ● ● | ● ● | ● ● +BM +EM | ● ● | ● ● BM |
| Statuario Oro | ● ● | ● ● | ● ● | ● ● +BM +EM | ● ● | ● ● BM |
| Titan White | ● ● | ● ● | ● ● | ● ● | | |
| Verde Aver | | | | | | |

Rettificate monocalibro Rectified monocaliber Rectifiés calibre unique Rektifiziert Monokaliber

* Non rettificato Unrectified Non rectifié Nicht kalibriert

● Honed R9
● Lucida
BM bookmatch
EM endmatch

PEZZI SPECIALI | TRIMS | ACCESSOIRES | FORMSTÜCKE

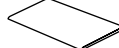
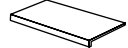
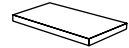
|  Battiscopa Bullnose Plinthe à bord arrondi Stehsockel |  Gradino Step tread Nez de marche Stufenplatte |  Gradone (assemblato) |  Angolare (assemblato) |
|--|--|--|--|
| cm 7x60 2 ^{3/4} "x23 ^{5/8} " | cm 30x60 11 ^{3/4} "x23 ^{5/8} " | cm 120x33x4 47 ^{1/4} "x13"x1 ^{5/8} " | cm 120x33x4 47 ^{1/4} "x13"x1 ^{5/8} " |
| cm 7x90 2 ^{3/4} "x35 ^{3/8} " | cm 30x90 11 ^{3/4} "x35 ^{3/8} " | cm 180x33x4 70 ^{7/8} "x13"x1 ^{5/8} " | cm 180x33x4 70 ^{7/8} "x13"x1 ^{5/8} " |

BOOKMATCH cm 160x320_mm 12

Non rettificata Unrectified Non rectifié Nicht kalibriert

calacatta extra

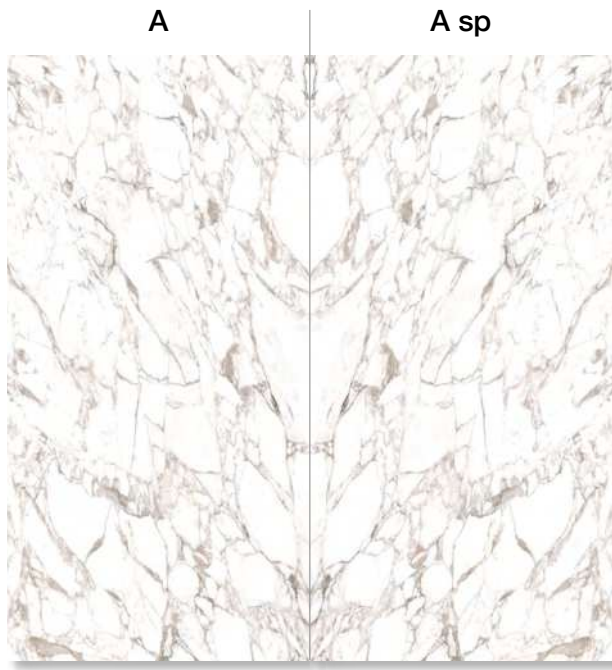

| | |
|------|------|
| A | A sp |
| A sp | A |



| | |
|------|------|
| A sp | A |
| A | A sp |

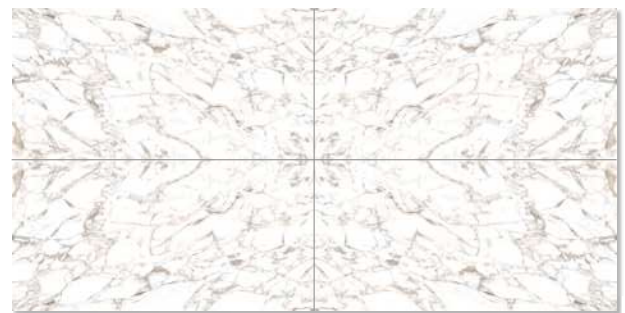

extra oro

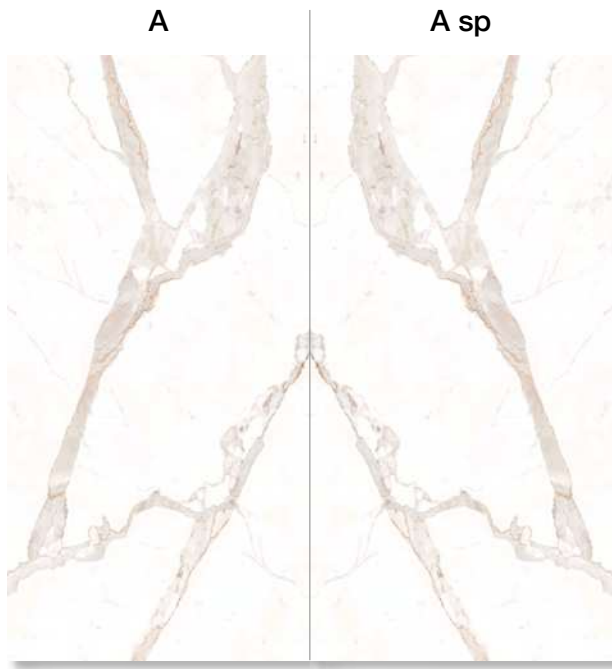

| | |
|------|------|
| A | A sp |
| A sp | A |

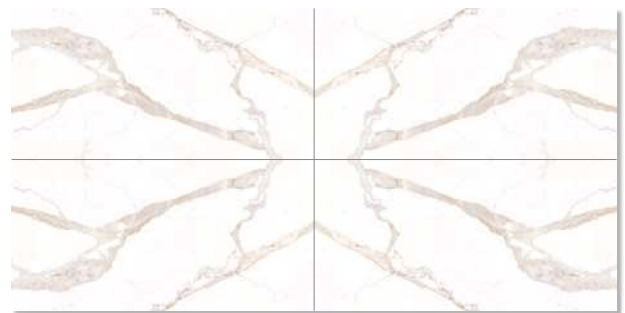

| | |
|------|------|
| A sp | A |
| A | A sp |

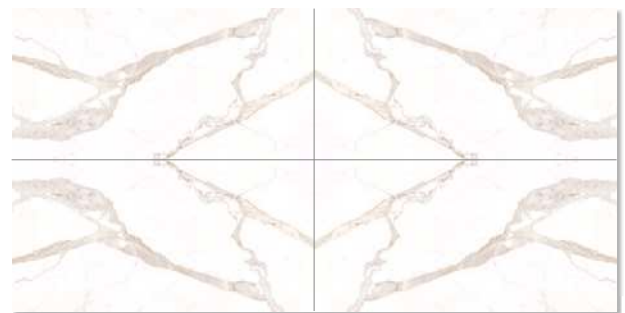

Prima di procedere alla posa dei decori endmatch o bookmatch, effettuare una preventiva ispezione visiva degli elementi appena rimossi dagli imballi al fine di verificare abbinamento reciproco, orientamento e disposizione delle lastre che compongono il decoro. La continuità di venatura fra le lastre è soggetta ad una tolleranza di 20 mm. Before you start laying the Endmatch or Bookmatch decorative tiles, make sure to visually check all the elements in the packaging to verify their orientation and arrangement and ensure they fit together. Veining continuity between the tiles is subject to a 20 mm tolerance. Avant de procéder à la pose des motifs endmatch ou bookmatch, effectuer au préalable une inspection visuelle des éléments venant d'être retirés des emballages afin de vérifier l'association réciproque, l'orientation et la disposition des dalles qui composent le motif. La continuité des veines entre les dalles est sujette à une tolérance de 20 mm. Bevor Sie mit der Verlegung der Endmatch- oder Bookmatch-Dekors fortfahren, sollten Sie eine vorläufige Sichtprüfung der gerade aus der Verpackung entnommenen Elemente durchführen, um die gegenseitige Übereinstimmung, Ausrichtung und Anordnung der Platten zu überprüfen, aus denen sich das Dekor zusammensetzt. Die Kontinuität der Meraserung zwischen den Platten unterliegt einer Toleranz von 20 mm.

Matching estetici a pagina: Matches on page: Correspondance esthétiques à la page : Ästhetische Übereinstimmung auf Seite: **529**

BOOKMATCH cm 160x320_mm 12

Non rettificata Unrectified Non rectifié Nicht kalibriert

statuario altissimo

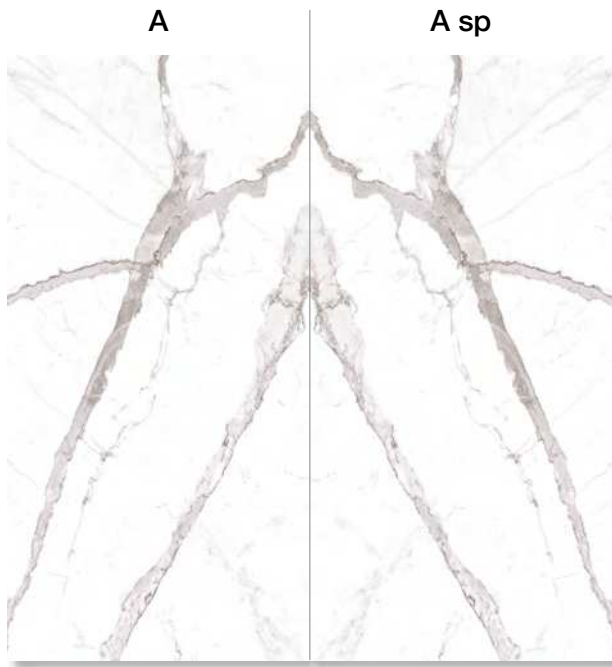

| | |
|------|------|
| A | A sp |
| A sp | A |

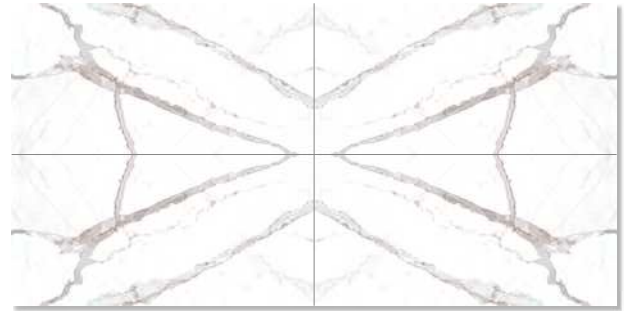

| | |
|------|------|
| A sp | A |
| A | A sp |

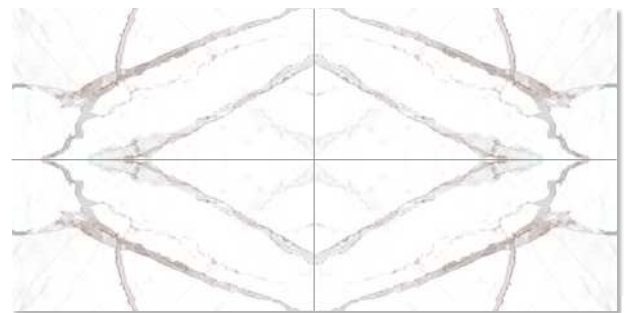

statuario fine

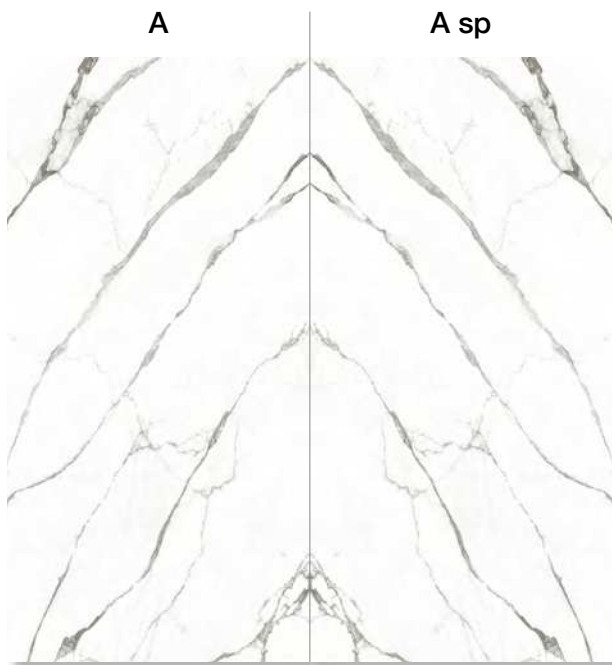

| | |
|------|------|
| A | A sp |
| A sp | A |

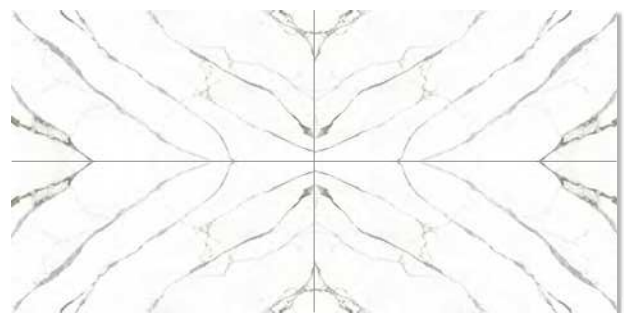

| | |
|------|------|
| A sp | A |
| A | A sp |

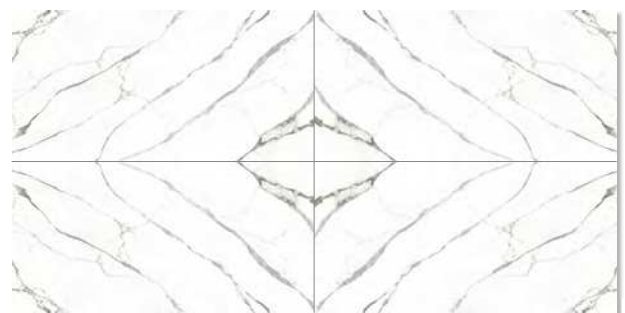

Prima di procedere alla posa dei decori endmatch o bookmatch, effettuare una preventiva ispezione visiva degli elementi appena rimossi dagli imballi al fine di verificare abbinamento reciproco, orientamento e disposizione delle lastre che compongono il decoro. La continuità di venatura fra le lastre è soggetta ad una tolleranza di 20 mm. Before you start laying the Endmatch or Bookmatch decorative tiles, make sure to visually check all the elements in the packaging to verify their orientation and arrangement and ensure they fit together. Veining continuity between the tiles is subject to a 20 mm tolerance. Avant de procéder à la pose des motifs endmatch ou bookmatch, effectuer au préalable une inspection visuelle des éléments venant d'être retirés des emballages afin de vérifier l'association réciproque, l'orientation et la disposition des dalles qui composent le motif. La continuité des veines entre les dalles est sujette à une tolérance de 20 mm. Bevor Sie mit der Verlegung der Endmatch- oder Bookmatch-Dekors fortfahren, sollten Sie eine vorläufige Sichtprüfung der gerade aus der Verpackung entnommenen Elemente durchführen, um die gegenseitige Übereinstimmung, Ausrichtung und Anordnung der Platten zu überprüfen, aus denen sich das Dekor zusammensetzt. Die Kontinuität der Maserung zwischen den Platten unterliegt einer Toleranz von 20 mm.

Matching estetici a pagina: Matches on page: Correspondance esthétiques à la page : Ästhetische Übereinstimmung auf Seite: 529

BOOKMATCH cm 160x320_mm 12

Non rettificata Unrectified Non rectifié Nicht kalibriert

statuario grigio



| | |
|------|------|
| A | A sp |
| A sp | A |

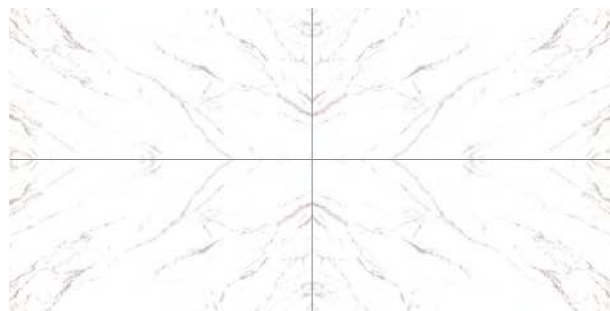

| | |
|------|------|
| A sp | A |
| A | A sp |

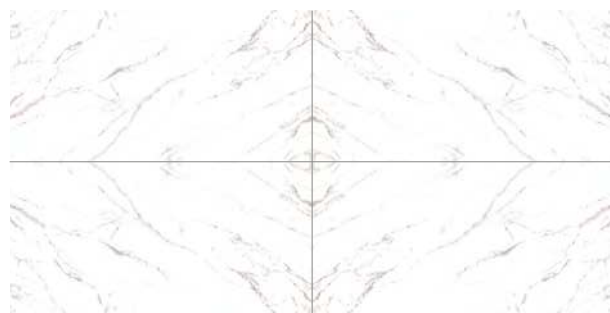

statuario oro

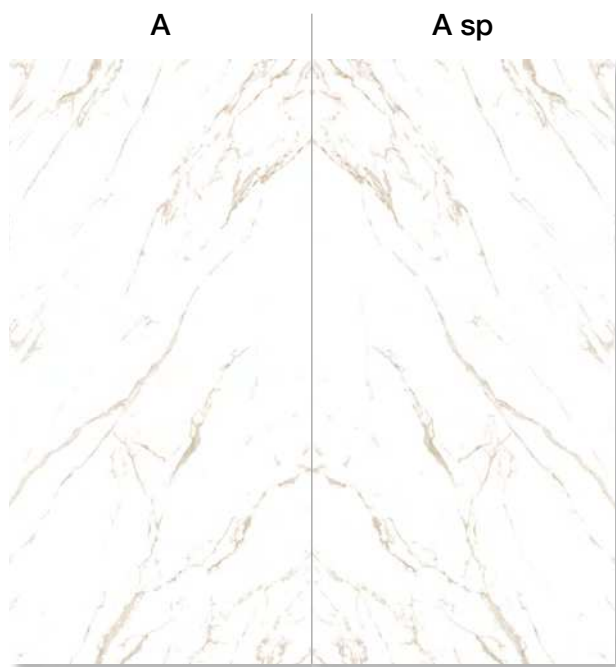

| | |
|------|------|
| A | A sp |
| A sp | A |

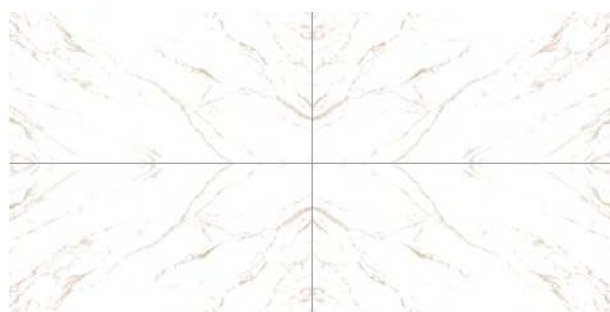

| | |
|------|------|
| A sp | A |
| A | A sp |

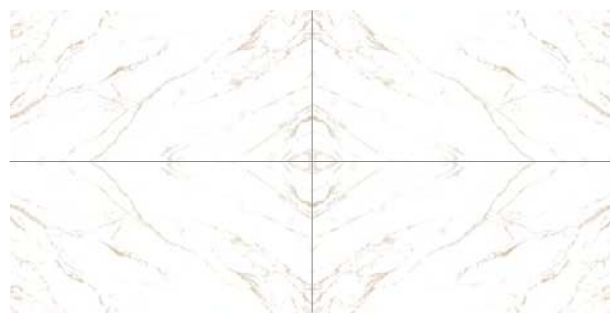

Prima di procedere alla posa dei decori endmatch o bookmatch, effettuare una preventiva ispezione visiva degli elementi appena rimossi dagli imballi al fine di verificare abbinamento reciproco, orientamento e disposizione delle lastre che compongono il decoro. La continuità di venatura fra le lastre è soggetta ad una tolleranza di 20 mm. Before you start laying the Endmatch or Bookmatch decorative tiles, make sure to visually check all the elements in the packaging to verify their orientation and arrangement and ensure they fit together. Veining continuity between the tiles is subject to a 20 mm tolerance. Avant de procéder à la pose des motifs endmatch ou bookmatch, effectuer au préalable une inspection visuelle des éléments venant d'être retirés des emballages afin de vérifier l'association réciproque, l'orientation et la disposition des dalles qui composent le motif. La continuité des veines entre les dalles est sujette à une tolérance de 20 mm. Bevor Sie mit der Verlegung der Endmatch- oder Bookmatch-Dekors fortfahren, sollten Sie eine vorläufige Sichtprüfung der gerade aus der Verpackung entnommenen Elemente durchführen, um die gegenseitige Übereinstimmung, Ausrichtung und Anordnung der Platten zu überprüfen, aus denen sich das Dekor zusammensetzt. Die Kontinuität der Maserung zwischen den Platten unterliegt einer Toleranz von 20 mm.

Matching estetici a pagina: Matches on page: Correspondance esthétiques à la page : Ästhetische Übereinstimmung auf Seite: 529

BOOKMATCH cm 160x320_mm 12

Non rettificate Unrectified Non rectifié Nicht kalibriert

carrara



| | |
|------|------|
| A | A sp |
| A sp | A |



| | |
|------|------|
| A sp | A |
| A | A sp |



deep dark

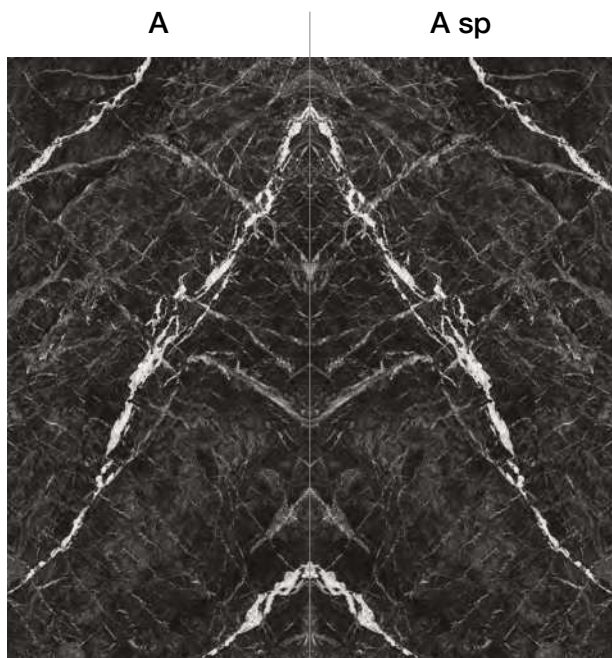

| | |
|------|------|
| A | A sp |
| A sp | A |

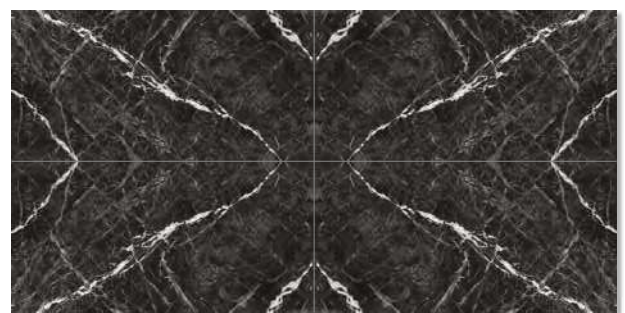

| | |
|------|------|
| A sp | A |
| A | A sp |

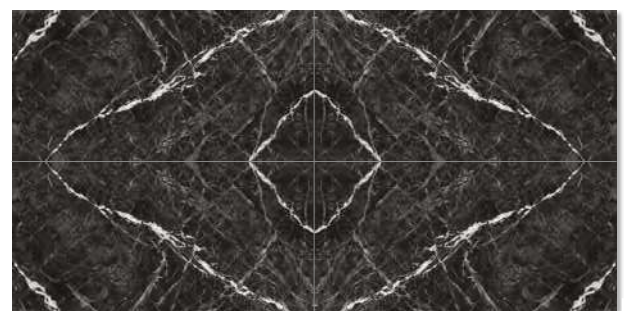

Prima di procedere alla posa dei decori endmatch o bookmatch, effettuare una preventiva ispezione visiva degli elementi appena rimossi dagli imballi al fine di verificare abbinamento reciproco, orientamento e disposizione delle lastre che compongono il decoro. La continuità di venatura fra le lastre è soggetta ad una tolleranza di 20 mm. Before you start laying the Endmatch or Bookmatch decorative tiles, make sure to visually check all the elements in the packaging to verify their orientation and arrangement and ensure they fit together. Veining continuity between the tiles is subject to a 20 mm tolerance. Avant de procéder à la pose des motifs endmatch ou bookmatch, effectuer au préalable une inspection visuelle des éléments venant d'être retirés des emballages afin de vérifier l'association réciproque, l'orientation et la disposition des dalles qui composent le motif. La continuité des veines entre les dalles est sujette à une tolérance de 20 mm. Bevor Sie mit der Verlegung der Endmatch- oder Bookmatch-Dekors fortfahren, sollten Sie eine vorläufige Sichtprüfung der gerade aus der Verpackung entnommenen Elemente durchführen, um die gegenseitige Übereinstimmung, Ausrichtung und Anordnung der Platten zu überprüfen, aus denen sich das Dekor zusammensetzt. Die Kontinuität der Maserung zwischen den Platten unterliegt einer Toleranz von 20 mm.

Matching estetici a pagina: Matches on page: Correspondance esthétiques à la page : Ästhetische Übereinstimmung auf Seite: 529

BOOKMATCH cm 160x320_mm 12

Non rettificate Unrectified Non rectifié Nicht kalibriert

night storm

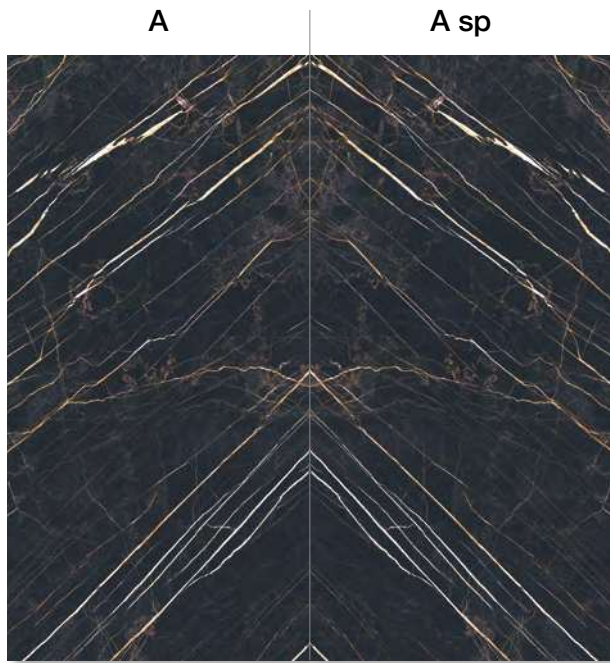

| | |
|------|------|
| A | A sp |
| A sp | A |



| | |
|------|------|
| A sp | A |
| A | A sp |



starry night

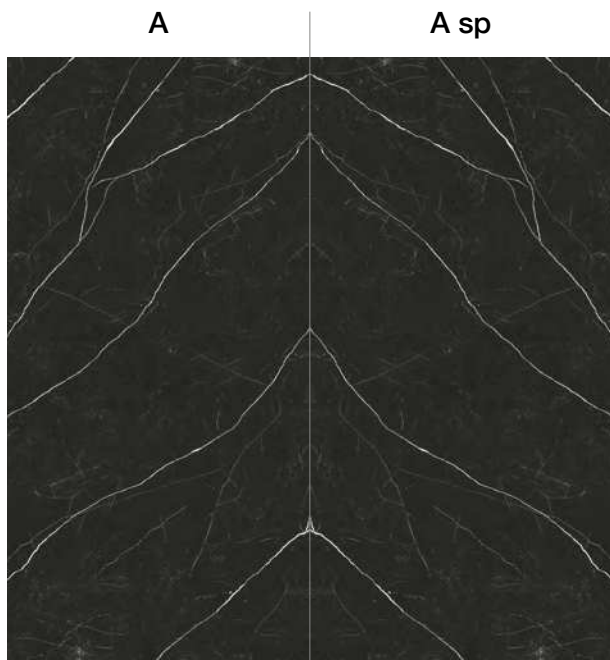

| | |
|------|------|
| A | A sp |
| A sp | A |



| | |
|------|------|
| A sp | A |
| A | A sp |



Prima di procedere alla posa dei decori endmatch o bookmatch, effettuare una preventiva ispezione visiva degli elementi appena rimossi dagli imballi al fine di verificare abbinamento reciproco, orientamento e disposizione delle lastre che compongono il decoro. La continuità di venatura fra le lastre è soggetta ad una tolleranza di 20 mm. Before you start laying the Endmatch or Bookmatch decorative tiles, make sure to visually check all the elements in the packaging to verify their orientation and arrangement and ensure they fit together. Veining continuity between the tiles is subject to a 20 mm tolerance. Avant de procéder à la pose des motifs endmatch ou bookmatch, effectuer au préalable une inspection visuelle des éléments venant d'être retirés des emballages afin de vérifier l'association réciproque, l'orientation et la disposition des dalles qui composent le motif. La continuité des veines entre les dalles est sujette à une tolérance de 20 mm. Bevor Sie mit der Verlegung der Endmatch- oder Bookmatch-Dekors fortfahren, sollten Sie eine vorläufige Sichtprüfung der gerade aus der Verpackung entnommenen Elemente durchführen, um die gegenseitige Übereinstimmung, Ausrichtung und Anordnung der Platten zu überprüfen, aus denen sich das Dekor zusammensetzt. Die Kontinuität der Maserung zwischen den Platten unterliegt einer Toleranz von 20 mm.

Matching estetici a pagina: Matches on page: Correspondance esthétiques à la page : Ästhetische Übereinstimmung auf Seite: 529

BOOKMATCH cm 120x278 mm 6

Rettificate monocalibro Rectified monocaliber Rectifiés calibre unique Rektifiziert Monokaliber

calacatta extra



| | |
|------|------|
| A | A sp |
| A sp | A |

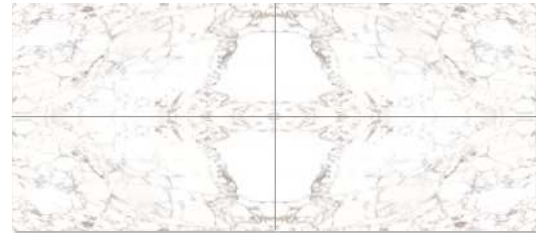

| | |
|------|------|
| A sp | A |
| A | A sp |



extra oro



| | |
|------|------|
| A | A sp |
| A sp | A |

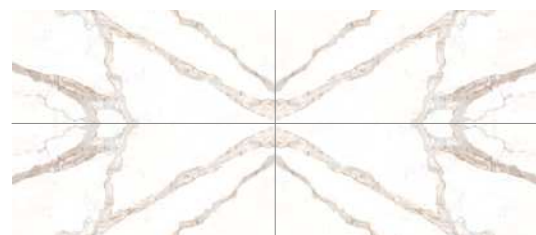

| | |
|------|------|
| A sp | A |
| A | A sp |

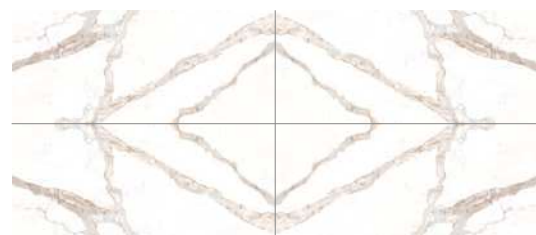

Prima di procedere alla posa dei decori endmatch o bookmatch, effettuare una preventiva ispezione visiva degli elementi appena rimossi dagli imballi al fine di verificare abbinamento reciproco, orientamento e disposizione delle lastre che compongono il decoro. La continuità di venatura fra le lastre è soggetta ad una tolleranza di 20 mm. Before you start laying the Endmatch or Bookmatch decorative tiles, make sure to visually check all the elements in the packaging to verify their orientation and arrangement and ensure they fit together. Veining continuity between the tiles is subject to a 20 mm tolerance. Avant de procéder à la pose des motifs endmatch ou bookmatch, effectuer au préalable une inspection visuelle des éléments venant d'être retirés des emballages afin de vérifier l'association réciproque, l'orientation et la disposition des dalles qui composent le motif. La continuité des veines entre les dalles est sujette à une tolérance de 20 mm. Bevor Sie mit der Verlegung der Endmatch- oder Bookmatch-Dekors fortfahren, sollten Sie eine vorläufige Sichtprüfung der gerade aus der Verpackung entnommenen Elemente durchführen, um die gegenseitige Übereinstimmung, Ausrichtung und Anordnung der Platten zu überprüfen, aus denen sich das Dekor zusammensetzt. Die Kontinuität der Maserung zwischen den Platten unterliegt einer Toleranz von 20 mm.

Matching estetici a pagina: Matches on page: Correspondance esthétiques à la page : Ästhetische Übereinstimmung auf Seite: 529

BOOKMATCH cm 120x278 mm 6

Rettificate monocalibro Rectified monocaliber Rectifiés calibre unique Rektifiziert Monokaliber

statuario altissimo

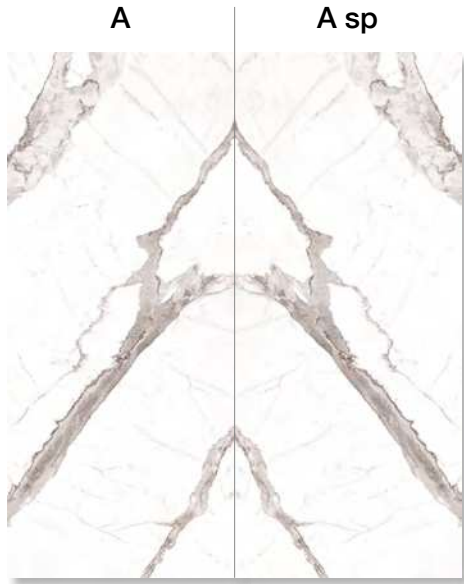

| | |
|------|------|
| A | A sp |
| A sp | A |

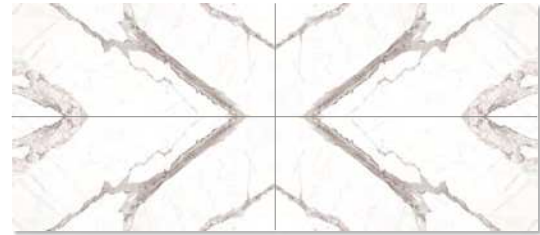

| | |
|------|------|
| A sp | A |
| A | A sp |

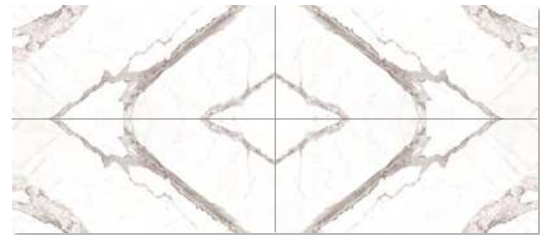

statuario fine

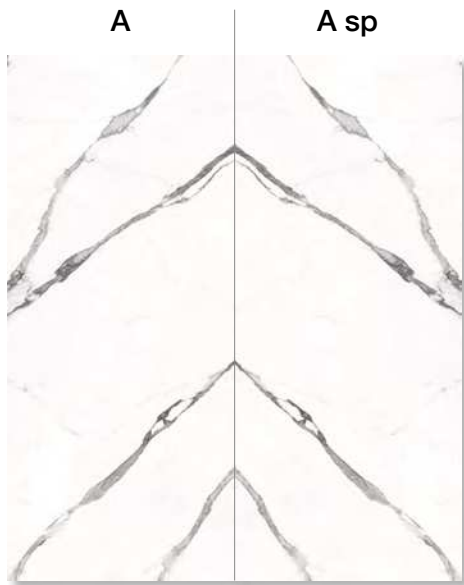

| | |
|------|------|
| A | A sp |
| A sp | A |

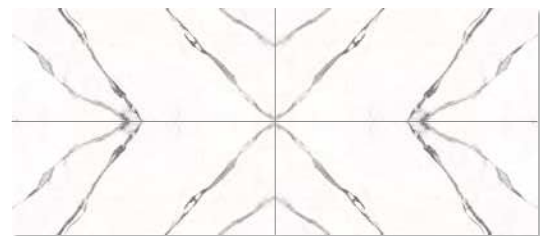

| | |
|------|------|
| A sp | A |
| A | A sp |

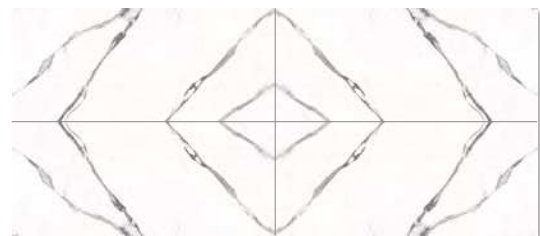

Prima di procedere alla posa dei decori endmatch o bookmatch, effettuare una preventiva ispezione visiva degli elementi appena rimossi dagli imballi al fine di verificare abbinamento reciproco, orientamento e disposizione delle lastre che compongono il decoro. La continuità di venatura fra le lastre è soggetta ad una tolleranza di 20 mm. Before you start laying the Endmatch or Bookmatch decorative tiles, make sure to visually check all the elements in the packaging to verify their orientation and arrangement and ensure they fit together. Veining continuity between the tiles is subject to a 20 mm tolerance. Avant de procéder à la pose des motifs endmatch ou bookmatch, effectuer au préalable une inspection visuelle des éléments venant d'être retirés des emballages afin de vérifier l'association réciproque, l'orientation et la disposition des dalles qui composent le motif. La continuité des veines entre les dalles est sujette à une tolérance de 20 mm. Bevor Sie mit der Verlegung der Endmatch- oder Bookmatch-Dekors fortfahren, sollten Sie eine vorläufige Sichtprüfung der gerade aus der Verpackung entnommenen Elemente durchführen, um die gegenseitige Übereinstimmung, Ausrichtung und Anordnung der Platten zu überprüfen, aus denen sich das Dekor zusammensetzt. Die Kontinuität der Maserung zwischen den Platten unterliegt einer Toleranz von 20 mm.

BOOKMATCH cm 120x278 mm 6

Rettificate monocalibro Rectified monocaliber Rectifiés calibre unique Rektifiziert Monokaliber

statuario grigio



| | |
|------|------|
| A | A sp |
| A sp | A |

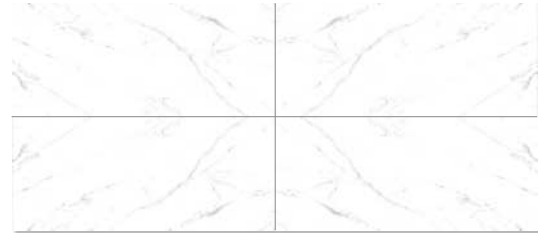

| | |
|------|------|
| A sp | A |
| A | A sp |



statuario oro

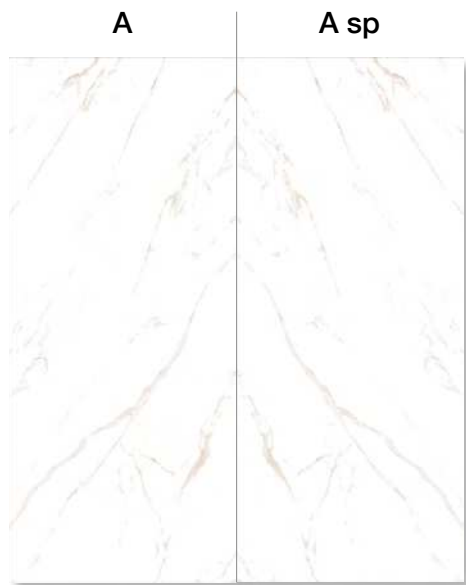

| | |
|------|------|
| A | A sp |
| A sp | A |



| | |
|------|------|
| A sp | A |
| A | A sp |



Prima di procedere alla posa dei decori endmatch o bookmatch, effettuare una preventiva ispezione visiva degli elementi appena rimossi dagli imballi al fine di verificare abbinamento reciproco, orientamento e disposizione delle lastre che compongono il decoro. La continuità di venatura fra le lastre è soggetta ad una tolleranza di 20 mm. Before you start laying the Endmatch or Bookmatch decorative tiles, make sure to visually check all the elements in the packaging to verify their orientation and arrangement and ensure they fit together. Veining continuity between the tiles is subject to a 20 mm tolerance. Avant de procéder à la pose des motifs endmatch ou bookmatch, effectuer au préalable une inspection visuelle des éléments venant d'être retirés des emballages afin de vérifier l'association réciproque, l'orientation et la disposition des dalles qui composent le motif. La continuité des veines entre les dalles est sujette à une tolérance de 20 mm. Bevor Sie mit der Verlegung der Endmatch- oder Bookmatch-Dekors fortfahren, sollten Sie eine vorläufige Sichtprüfung der gerade aus der Verpackung entnommenen Elemente durchführen, um die gegenseitige Übereinstimmung, Ausrichtung und Anordnung der Platten zu überprüfen, aus denen sich das Dekor zusammensetzt. Die Kontinuität der Maserung zwischen den Platten unterliegt einer Toleranz von 20 mm.

Matching estetici a pagina: Matches on page: Correspondance esthétiques à la page : Ästhetische Übereinstimmung auf Seite: 529

BOOKMATCH cm 120x240_mm 6

Rettificate monocalibro Rectified monocaliber Rectifiés calibre unique Rektifiziert Monokaliber

fior di pesco

| | |
|------|------|
| A | A sp |
| A sp | A |



| | |
|------|------|
| A sp | A |
| A | A sp |



Prima di procedere alla posa dei decori endmatch o bookmatch, effettuare una preventiva ispezione visiva degli elementi appena rimossi dagli imballi al fine di verificare abbinamento reciproco, orientamento e disposizione delle lastre che compongono il decoro. La continuità di venatura fra le lastre è soggetta ad una tolleranza di 20 mm. Before you start laying the Endmatch or Bookmatch decorative tiles, make sure to visually check all the elements in the packaging to verify their orientation and arrangement and ensure they fit together. Veining continuity between the tiles is subject to a 20 mm tolerance. Avant de procéder à la pose des motifs endmatch ou bookmatch, effectuer au préalable une inspection visuelle des éléments venant d'être retirés des emballages afin de vérifier l'association réciproque, l'orientation et la disposition des dalles qui composent le motif. La continuité des veines entre les dalles est sujette à une tolérance de 20 mm. Bevor Sie mit der Verlegung der Endmatch- oder Bookmatch-Dekors fortfahren, sollten Sie eine vorläufige Sichtprüfung der gerade aus der Verpackung entnommenen Elemente durchführen, um die gegenseitige Übereinstimmung, Ausrichtung und Anordnung der Platten zu überprüfen, aus denen sich das Dekor zusammensetzt. Die Kontinuität der Maserung zwischen den Platten unterliegt einer Toleranz von 20 mm.

Matching estetici a pagina: Matches on page: Correspondance esthétiques à la page : Ästhetische Übereinstimmung auf Seite: **529**



WALL: statuario oro endmatch cm 120x278 - 47^{1/4}"x109^{1/2}" / FLOOR: statuario oro lucida cm 120x120 - 47^{1/4}"x47^{1/4}"

ENDMATCH cm 120x278 mm 6

Rettificate monocalibro Rectified monocaliber Rectifiés calibre unique Rektifiziert Monokaliber

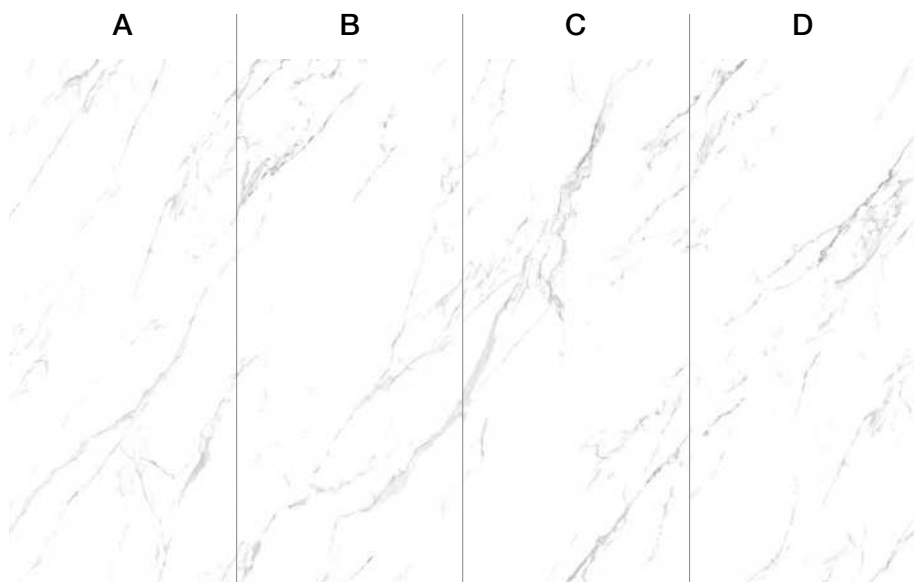
statuario grigio**statuario oro**

Endmatch: per ottenere una sequenza continua tra le quattro facce (A, B, C, D), è necessario specificare la richiesta al momento dell'ordine. Le facce devono essere sempre ordinate come pacchetto completo composto da una A, una B, una C e una D, rispettando la disposizione originale in fase di installazione per garantire la continuità del motivo. Please specify whether you need a continuous sequence of all four faces (A, B, C, D) in the order. Tile faces must be ordered as a complete pack (A, B, C, D), and the tiles must be laid according to the original arrangement to ensure the motif's continuity. **Pour obtenir une séquence continue entre les quatre faces (A, B, C, D), la demande doit être spécifiée lors de la commande. Les faces doivent toujours être commandées comme un ensemble complet composé d'une A, d'une B, d'une C et d'une D, en respectant la disposition d'origine lors de la pose afin d'assurer la continuité du motif.** Um einen kontinuierlichen Übergang zwischen den vier Plattenflächen (A, B, C, D) zu erhalten, muss der Wunsch nach dieser Variante bei der Bestellung angegeben werden. Die Flächen müssen immer als Komplettpaket bestehend aus einer A-, einer B-, einer C- und einer D-Plattenfläche bestellt werden. Bei der Installation muss die ursprüngliche Anordnung eingehalten werden, um die Kontinuität des Musters zu gewährleisten.

Prima di procedere alla posa dei decori endmatch o bookmatch, effettuare una preventiva ispezione visiva degli elementi appena rimossi dagli imballi al fine di verificare abbinamento reciproco, orientamento e disposizione delle lastre che compongono il decoro. La continuità di venatura fra le lastre è soggetta ad una tolleranza di 20 mm. Before you start laying the Endmatch or Bookmatch decorative tiles, make sure to visually check all the elements in the packaging to verify their orientation and arrangement and ensure they fit together. Veining continuity between the tiles is subject to a 20 mm tolerance. **Avant de procéder à la pose des motifs endmatch ou bookmatch, effectuer au préalable une inspection visuelle des éléments venant d'être retirés des emballages afin de vérifier l'association réciproque, l'orientation et la disposition des dalles qui composent le motif.** La continuité des veines entre les dalles est sujette à une tolérance de 20 mm. Bevor Sie mit der Verlegung der Endmatch- oder Bookmatch-Dekors fortfahren, sollten Sie eine vorläufige Sichtprüfung der gerade aus der Verpackung entnommenen Elemente durchführen, um die gegenseitige Übereinstimmung, Ausrichtung und Anordnung der Platten zu überprüfen, aus denen sich das Dekor zusammensetzt. Die Kontinuität der Maserung zwischen den Platten unterliegt einer Toleranz von 20 mm.

Matching estetici a pagina: Matches on page: Correspondance esthétiques à la page : Ästhetische Übereinstimmung auf Seite: **529**

DECORI | DECORS | DÉCORS | DEKORE

mosaico ■

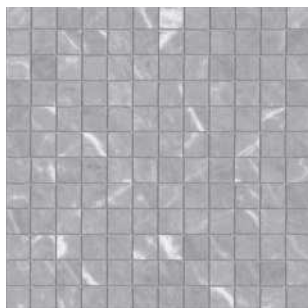

cm 30x30 - 11³/₄"x11³/₄"
tessera cm 2,3x2,3 - 1"x1"
su rete on net sur trame auf Netz

▽ mm 9

mosaico 5x10 ■



cm 30x30 - 11³/₄"x11³/₄"
tessera cm 5x10 - 2"x4"
su rete on net sur trame auf Netz

▽ mm 9

■ Disponibile in tutti i colori della serie, superficie honed e lucida
Available in all the colours of the series, honed and lucida surface
Disponible dans toutes les couleurs de la série, surface noned et lucida
Verfügbar in allen Farben, honed und lucida Oberfläche

esagoni ● *

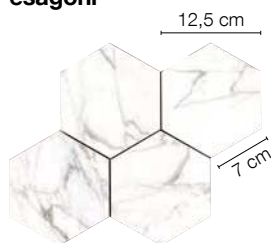

cm 21,5x25 - 8¹/₂"x9⁷/₈"
su rete on net sur trame auf Netz

▽ mm 9

esagoni 3D ● **



cm 21,5x25 - 8¹/₂"x9⁷/₈"
su rete on net sur trame auf Netz

▽ mm 9

● Solo superficie lucida
Lucida surface only
Seulement surface lucida
Nur in lucida Oberfläche

* Disponibile nei colori:
Available in the colours:
Disponible dans les couleurs:
Verfügbar in den folgenden Farben:
**Bardiglio Imperiale, Canova, Crema Select,
Deep Dark, Pulpis Tortora, Statuario Grigio,
Statuario Oro**

** Bardiglio Imperiale, Deep Dark, Statuario Grigio

rosone marmoker

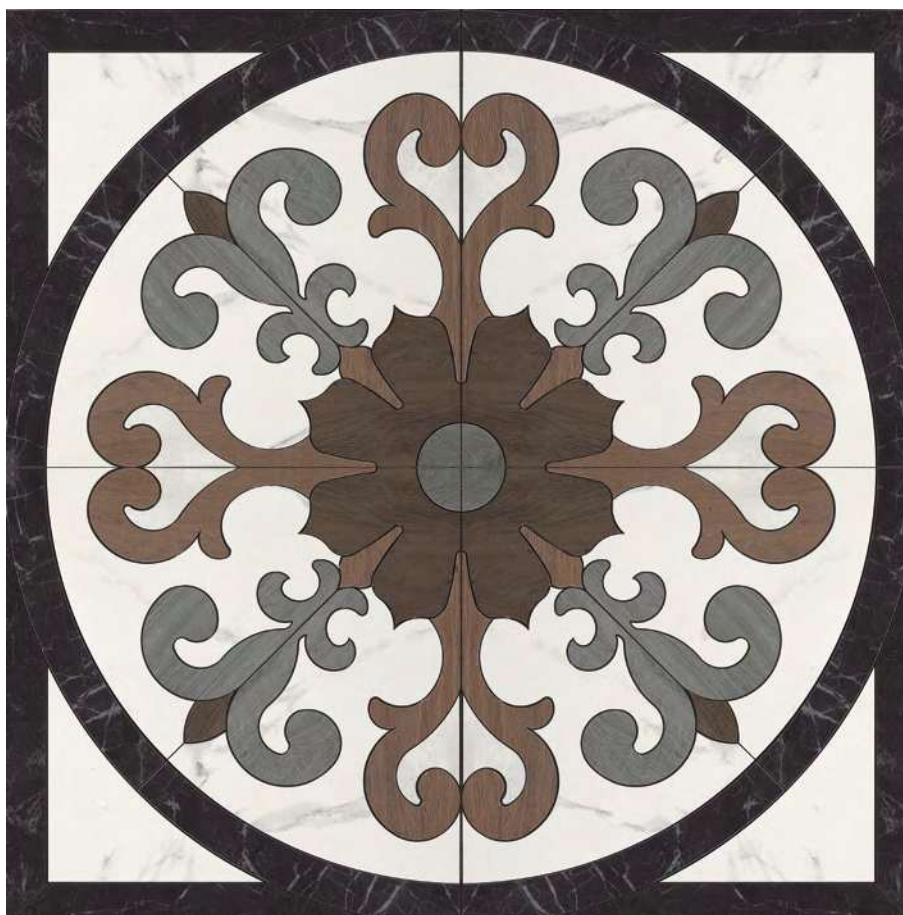











cm 120x120 - 47¹/₄"x47¹/₄"
statuario grigio, deep dark, tavolato antracite, tavolato marrone medio, tavolato marrone scuro
Solo superficie lucida Lucida surface only Seulement surface lucida Nur in lucida Oberfläche

CARATTERISTICHE TECNICHE TECHNICAL FEATURES

CARACTÉRISTIQUES TECHNIQUES TECHNISCHE EIGENSCHAFTEN



| | norma standards norme Norm | risultato prova* test results* resultats des essais* Ergebnisse* |
|---|--|---|
|  classificazione prodotto product classification classement Klassifizierung | UNI EN 14411-G ISO 13006 | gruppo Bla completamente greificato group Bla fully vitrified group Bla grès cérame fin Gruppe Bla Feinsteinzeug |
|  caratteristiche dimensionali e d'aspetto dimensional and surface quality caractéristiques de la surface Oberflächenqualität | UNI EN ISO 10545-2 | tolleranze minime nella 1ª scelta very low tolerance des tolérances minimales en 1er choix Entspricht Normen |
|  assorbimento di acqua water absorption absorption d'eau Wasseraufnahme | UNI EN ISO 10545-3 | < 0,1% |
|  resistenza alla flessione flexural strength résistance à la flexion Biegezugfestigkeit | UNI EN ISO 10545-4 | 45 N/mm ² |
|  resistenza al gelo frost resistance résistance au gel Frostwiderstandsfähigkeit | qualsiasi norma all standards toute norme alle normen | garantita guaranteed garantie Garantiert |
|  resistenza attacco chimico (esclusione acido fluoridrico) resistance to acids and alkalis (with the exception of hydrofluoric acid) résistance à l'attaque chimique (exclusion de l'acide fluorhydrique) Säure und Laugen Beständigkeit (mit Ausnahme von Fluorwasserstoff) | UNI EN ISO 10545-13 | A |
|  resistenza usura e abrasione wear and abrasion resistance résistance à l'usure et abrasion Abriebhärte | UNI EN ISO 10545-6 | ≤ 150 mm ³ |
|  dilatazione termica lineare linear thermal expansion coefficient linéaire de dilatation thermique Lineare Wärmeausdehnung | UNI EN ISO 10545-8 | 6 x 10 ⁻⁶ |
|  resistenza alle macchie stain resistance résistance aux taches Fleckenfestigkeit | UNI EN ISO 10545-14 | 4 - 5 garantita guaranteed garantie Garantiert |
|  resistenza alla scivolosità (Superficie Naturale) slip resistance (Matt surface) résistance au glissement (Surface naturelle) Trittsicherheit (Natur Oberflächen) | DIN EN 16165 ANNEX B - ANNEX A D.M. N° 236 DEL 14.06.89 METODO B.C.R. BS 7976-2:2002 + A1:2013 | Honed R9 Honed R10 A+B* valore μ > 0,40 Honed R10 PTV > 36*** |
|  resistenza dei colori alla luce colour resistance to sunlight exposure résistance de la couleur à la lumière Unveränderlichkeit der Farben wenn Strahlung zugesetzt wird | DIN 51094 | nessuna variazione no change of colours couleurs inchangées Keinerlei Farbänderung |

* valore indicativo approx value donnée approximative Ungefähre Werte

** si rimanda all'elenco prodotti UPEC ufficiale, consultabile sul sito: please see the official UPEC product list:

veuillez consulter la liste officielle produits UPEC: siehe die offizielle UPEC-Produktliste auf der Website: <http://evaluation.cstb.fr>

*** Valore indicativo, superficie bagnata ed asciutta Approx value, wet and dry surface Valeur approximative, surface humide et sèche Näherungswert, nasse und trockene Oberfläche

• Non idonea per destinazione d'uso spiaggia piscina e/o spogliatoi Not suitable for use for pool decks and/or changing rooms

Ne convient pas pour une destination d'usage comme plage de piscine et / ou vestiaire Nicht geeignet für Schwimmbekkenränder und/oder Umkleidekabinen

Al pari dei materiali naturali di riferimento, l'aspetto estetico, la differenza di tono e le venature possono essere diverse da piastrella a piastrella. Per una corretta comprensione della variabilità del prodotto è consigliabile prendere visione delle immagini a tutto ambiente sul catalogo di collezione, sul nostro sito all'indirizzo www.casalgrandepadana.it o chiedere maggiori informazioni ai nostri concessionari.

Just like the natural materials they are inspired by, the aesthetics, colouration and veining of the tiles can differ. To properly gauge the suitability of a product, we advise that you view the full-space photos that you can find in our collection catalogue and on our website at www.casalgrandepadana.com. Alternatively, please ask a reseller for more information.

Tout comme pour les matières naturelles de référence, la différence de tonalité, les veines ainsi que l'aspect esthétique peuvent varier d'une dalle à l'autre. Pour bien comprendre la variabilité du produit, il est conseillé de consulter les images d'ambiance présentes sur le catalogue de la collection, sur notre site à l'adresse www.casalgrandepadana.fr ou de demander plus d'informations à nos concessionnaires.

Wie bei den als Vorbild dienenden Naturmaterialien können sich auch hier das ästhetische Erscheinungsbild, der Farbtonunterschied und die Maserung von Fliese zu Fliese unterscheiden. Um die Variabilität des Produkts besser zu verstehen, raten wir Ihnen, die Bilder mit ausgestatteten Räumen im Kollektionskatalog auf unserer Website www.casalgrandepadana.de zu konsultieren. Weitere Informationen können Sie auch bei unseren Vertragshändlern erhalten.



**CASALGRANDE
PADANA**
THE GREEN WAY TO PAVE

via Statale 467, n. 73 - 42013 Casalgrande (Re) Italy
tel + 39 0522 9901 - fax + 39 0522 996121
info@casalgrandepadana.it - www.casalgrandepadana.com

